

**MADDEX**  
marketing s.r.o.

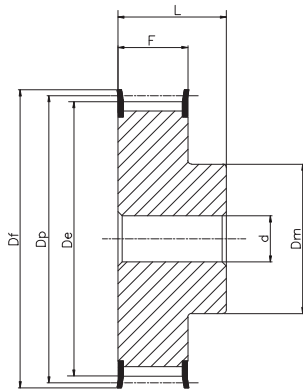

**PULEGGE DENTATE POLY CHAIN® GT®**

POLY CHAIN® GT® Timing belt pulleys  
POLY CHAIN® GT® Zahnriemenscheiben  
Poulies dentées POLY CHAIN® GT®  
Poleas dentadas POLY CHAIN® GT®



**Tipo / Type**  
**6F**

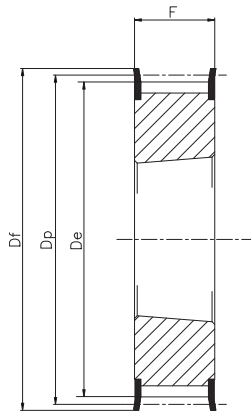

**Tipo / Type**  
**3F**

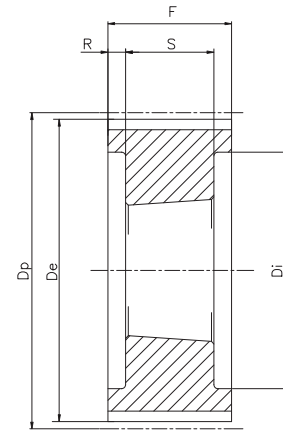

**Tipo / Type**  
**4**

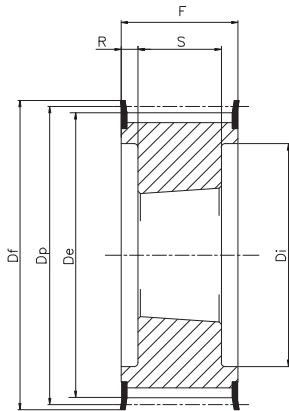

**Tipo / Type**  
**4F**

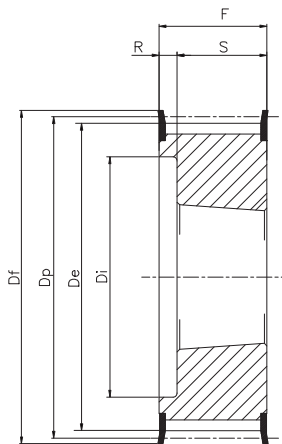

**Tipo / Type**  
**5F2**

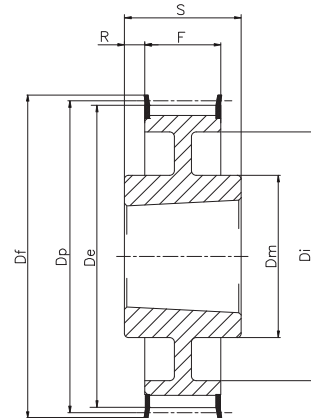

**Tipo / Type**  
**7WF**

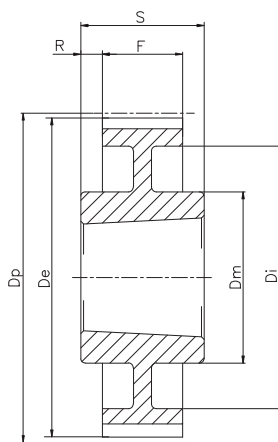

**Tipo / Type**  
**7W**

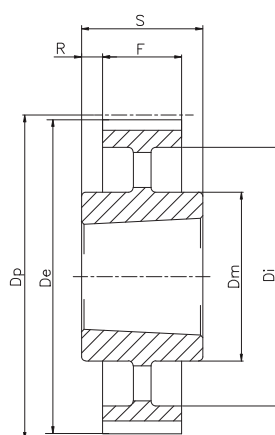

**Tipo / Type**  
**7A**

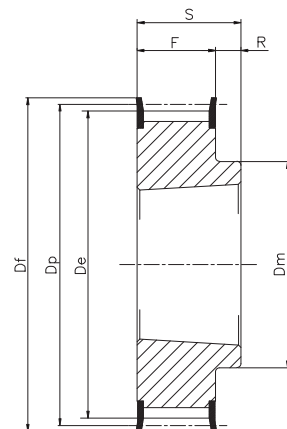

**Tipo / Type**  
**8F**

**Pulegge dentate POLY CHAIN® GT®**

**POLY CHAIN® GT® Timing belt pulleys / POLY CHAIN® GT® Zahnriemenscheiben**

**Poulies dentées POLY CHAIN® GT® / Poleas dentadas POLY CHAIN® GT®**

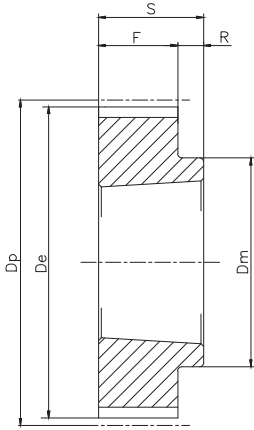

**Tipo / Type  
8**

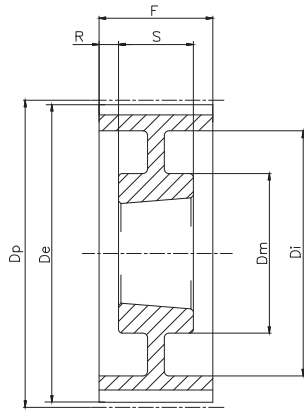

**Tipo / Type  
9W**

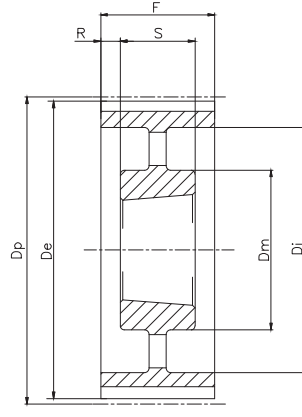

**Tipo / Type  
9A**

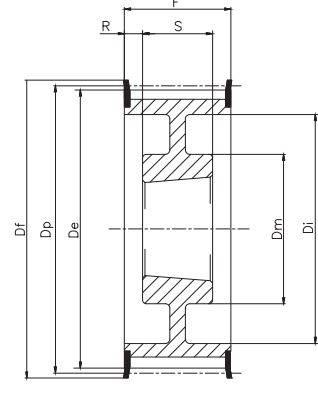

**Tipo / Type  
9WF**

**PC8M-12**

Caratteristiche Features Merkmal Características	Codice Code symbol Fabriknummer Code symbole Numero de fabrica	Nostro codice Our code Unser Code Notre code Nuestro codigo	Tipo Type Type Type Tipo	Codice flangia Flange code Bordscheiben-Code Code flasque Codigo brida	N. denti N. of teeth Zahnezahl N. bre de dents Cantidad de dientes	Foro d / Bussola. Bush d / Bore. Bohrung d / Buchse. Alesage d / Moyeu. Agujero d / Casquillo.	Dp	De	Df	Dm	Di	F	S	R	Peso Weight Gewicht Peso Kg
Acciaio / Steel / Stahl Acier / Acero	<b>PC8M-225-12</b>	<b>08M12022</b>	6F	FL053	22	12	56,02	54,42	60,0	43	-	20	30	10,0	0,54
	<b>TL PC8M-255-12</b>	<b>0812025</b>	8F	FL061	25	1108	63,66	62,06	70,0	49	-	20	22	2,0	0,49
	<b>TL PC8M-285-12</b>	<b>0812028</b>	8F	FL079	28	1108	71,30	69,70	75,0	56	-	20	22	2,0	0,66
	<b>TL PC8M-305-12</b>	<b>0812030</b>	8F	FL073	30	1210	76,39	74,79	83,0	60	-	20	25	5,0	0,83
	<b>TL PC8M-325-12</b>	<b>0812032</b>	8F	FL076	32	1610	81,49	79,89	87,0	66	-	20	25	5,0	0,93
	<b>TL PC8M-345-12</b>	<b>0812034</b>	8F	FL066	34	1610	86,58	84,98	91,0	68	-	20	25	5,0	1,05
	<b>TL PC8M-365-12</b>	<b>0812036</b>	8F	FL068	36	1610	91,67	90,07	97,0	74	-	20	25	5,0	1,17
	<b>TL PC8M-385-12</b>	<b>0812038</b>	8F	FL070	38	1610	96,77	95,17	102,0	80	-	20	25	5,0	1,29
	<b>TL PC8M-405-12</b>	<b>0812040</b>	8F	FL077	40	1610	101,86	100,26	106,0	85	-	20	25	5,0	1,43
	<b>TL PC8M-455-12</b>	<b>0812045</b>	8F	FL075	45	2012	114,59	112,99	120,0	92	-	20	32	12,0	2,30
	<b>TL PC8M-485-12</b>	<b>0812048</b>	8F	FL078	48	2012	122,23	120,63	128,0	100	-	20	32	12,0	2,49
	<b>TL PC8M-505-12</b>	<b>0812050</b>	8F	FL080	50	2012	127,32	125,72	135,0	104	-	20	32	12,0	2,70
	<b>TL PC8M-565-12</b>	<b>0812056</b>	8F	FL085	56	2012	142,60	141,00	150,0	104	-	20	32	12,0	3,88
<b>TL PC8M-605-12</b>	<b>0812060</b>	8F	FL086	60	2012	152,79	151,19	158,0	111	-	20	32	12,0	4,42	
<b>TL PC8M-645-12</b>	<b>0812064</b>	8F	FL090	64	2012	162,97	161,37	168,0	111	-	20	32	12,0	4,99	
Ghisa / Cast Iron Grauguss / Fonte Hierro fundido	<b>TL PC8M-755-12</b>	<b>0812075</b>	8	-	74	2012	190,99	189,39	-	111	-	20	32	12,0	6,90
	<b>TL PC8M-805-12</b>	<b>0812080</b>	8	-	80	2012	203,72	202,12	-	111	-	20	32	12,0	7,75
	<b>TL PC8M-905-12</b>	<b>0812090</b>	8	-	90	2012	229,18	227,58	-	111	-	20	32	12,0	9,94

**PC8M-21**

Caratteristiche Features Merkmal Características	Codice Code symbol Fabriknummer Code symbole Numero de fabrica	Nostro codice Our code Unser Code Notre code Nuestro codigo	Tipo Type Typ Tipo	Codice flangia Flange code Bordscheiben-Code Code flasque Código brida	N. denti N. of teeth Zahnezahl N. bre de dents Cantidad de dientes	Foro d / Bussola. Bush d / Bore. Bohrung d / Buchse. Alesage d / Moyeu. Agujero d / Casquillo.	Dp	De	Df	Dm	Di	F	S	R	Peso Weight Gewicht Poids Peso Kg
Acciaio / Steel / Stahl Acier / Acero	PC8M-225-21	08M21022	6F	FL053	22	12	56,02	54,42	60,0	43	-	30	40	10,0	0,73
	TL PC8M-255-21	0821025	3F	FL061	25	1108	63,66	62,06	70,0	-	-	30	-	-	0,49
	TL PC8M-285-21	0821028	3F	FL079	28	1210	71,30	69,70	75,0	-	-	30	-	-	0,85
	TL PC8M-305-21	0821030	3F	FL073	30	1210	76,39	74,79	83,0	-	-	30	-	-	0,97
	TL PC8M-325-21	0821032	3F	FL076	32	1610	81,49	79,89	87,0	-	-	30	-	-	1,09
	TL PC8M-345-21	0821034	3F	FL066	34	1610	86,58	84,98	91,0	-	-	30	-	-	1,22
	TL PC8M-365-21	0821036	3F	FL068	36	1610	91,67	90,07	97,0	-	-	30	-	-	1,36
	TL PC8M-385-21	0821038	3F	FL070	38	1610	96,77	95,17	102,0	-	-	30	-	-	1,51
	TL PC8M-405-21	0821040	3F	FL077	40	1610	101,86	100,26	106,0	-	-	30	-	-	1,66
	TL PC8M-455-21	0821045	8F	FL075	45	2012	114,59	112,99	120,0	92	-	30	32	2,0	2,30
	TL PC8M-485-21	0821048	8F	FL078	48	2012	122,23	120,63	128,0	100	-	30	32	2,0	2,49
	TL PC8M-505-21	0821050	8F	FL080	50	2012	127,32	125,72	135,0	104	-	30	32	2,0	2,70
	TL PC8M-565-21	0821056	8F	FL085	56	2012	142,60	141,00	150,0	111	-	30	32	2,0	3,88
TL PC8M-605-21	0821060	8F	FL086	60	2517	152,79	151,19	158,0	124	-	30	45	15,0	5,85	
TL PC8M-645-21	0821064	8F	FL090	64	2517	162,97	161,37	168,0	124	-	30	45	15,0	6,61	
Ghisa / Cast iron Grauguss / Fonte Hierro fundido	TL PC8M-755-21	0821075	8	-	75	2517	190,99	189,39	-	124	-	30	45	15,0	7,84
	TL PC8M-805-21	0821080	8	-	80	2517	203,72	202,12	-	124	-	30	45	15,0	9,45
	TL PC8M-905-21	0821090	7W	-	90	2517	229,18	227,58	-	124	198	30	45	7,5	11,55
	TL PC8M-1125-21	0821112	7W	-	112	2517	285,21	283,61	-	124	253	30	45	7,5	17,15
	TL PC8M-1405-21	0821140	7A	-	140	3020	356,51	354,91	-	150	324	30	51	10,5	33,25

**PC8M-36**

Caratteristiche Features Merkmal Características	Codice Code symbol Fabriknummer Code symbole Numero de fabrica	Nostro codice Our code Unser Code Notre code Nuestro codigo	Tipo Type Typ Tipo	Codice flangia Flange code Bordscheiben-Code Code flasque Código brida	N. denti N. of teeth Zahnezahl N. bre de dents Cantidad de dientes	Foro d / Bussola. Bush d / Bore. Bohrung d / Buchse. Alesage d / Moyeu. Agujero d / Casquillo.	Dp	De	Df	Dm	Di	F	S	R	Peso Weight Gewicht Poids Peso Kg
Acciaio / Steel / Stahl Acier / Acero	PC8M-255-36	08M36025	6F	FL061	25	12	63,66	62,06	70,0	49	-	45	55	10,0	1,09
	TL PC8M-285-36	0836028	3F	FL079	28	1210	71,30	69,70	75,0	-	-	45	-	-	1,21
	TL PC8M-305-36	0836030	3F	FL073	30	1610	76,39	74,79	83,0	-	-	45	-	-	1,38
	TL PC8M-325-36	0836032	3F	FL076	32	1610	81,89	79,89	87,0	-	-	45	-	-	1,56
	TL PC8M-345-36	0836034	3F	FL066	34	1610	86,58	84,98	91,0	-	-	45	-	-	1,75
	TL PC8M-365-36	0836036	3F	FL068	36	1610	91,67	90,07	97,0	-	-	45	-	-	1,95
	TL PC8M-385-36	0836038	3F	FL070	38	1610	96,77	95,17	102,0	-	-	45	-	-	2,16
	TL PC8M-405-36	0836040	3F	FL077	40	2012	101,86	100,26	106,0	-	-	45	-	-	2,38
	TL PC8M-455-36	0836045	3F	FL075	45	2012	114,59	112,99	120,0	-	-	45	-	-	3,11
	TL PC8M-485-36	0836048	3F	FL078	48	2012	122,23	120,63	128,0	-	-	45	-	-	3,37
	TL PC8M-505-36	0836050	3F	FL080	50	2012	127,32	125,72	135,0	-	-	45	-	-	3,64
	TL PC8M-565-36	0836056	3F	FL085	56	2517	142,60	141,00	150,0	-	-	45	-	-	5,14
	TL PC8M-605-36	0836060	3F	FL086	60	2517	152,79	151,19	158,0	-	-	45	-	-	5,85
TL PC8M-645-36	0836064	3F	FL090	64	2517	162,97	161,37	168,0	-	-	45	-	-	6,61	
Ghisa / Cast iron Grauguss / Fonte Hierro fundido	TL PC8M-755-36	0836075	8	-	75	3020	190,99	189,39	-	150	-	45	51	6,0	9,47
	TL PC8M-805-36	0836080	8	-	80	3020	203,72	202,12	-	150	-	45	51	6,0	10,64
	TL PC8M-905-36	0836090	7W	-	90	3020	229,18	227,58	-	150	197	45	51	3,0	13,64
	TL PC8M-1125-36	0836112	7W	-	112	3020	285,21	283,61	-	150	253	45	51	3,0	18,21
	TL PC8M-1405-36	0836140	7A	-	140	3020	356,51	354,91	-	150	324	45	51	3,0	24,92
	TL PC8M-1685-36	0836168	7A	-	168	3525	427,81	426,21	-	198	396	45	65	10,0	31,92
	TL PC8M-1925-36	0836192	7A	-	192	3525	488,92	487,32	-	198	457	45	65	10,0	45,92

**Pulegge dentate POLY CHAIN® GT®**

**POLY CHAIN® GT® Timing belt pulleys / POLY CHAIN® GT® Zahnriemenscheiben**

**Poulies dentées POLY CHAIN® GT® / Poleas dentadas POLY CHAIN® GT®**



**PC8M-62**

Caratteristiche Features Merkmale Características	Codice Code symbol Fabriknummer Code symbole Numero de fabrica	Nostro codice Our code Unser Code Notre code Nuestro codigo	Tipo Type Typ Type Tipo	Codice flangia Flange code Bordscheiben-Code Code flasque Código brida	N. denti N. of teeth Zahnezahl N. bre de dents Cantidad de dientes	Foro d / Bussola. Bush d / Bore. Bohrung d / Buchse. Alesage d / Moyeu. Agujero d / Casquillo.	Dp	De	Df	Dm	Di	F	S	R	Peso Weight Gewicht Poids Peso Kg	
Acciaio / Steel / Stahl Acier / Acero	con flangia / with flanges mit Flanges / avec flasques / con tapetas	<b>PC8M-30S-62</b>	<b>08M62030</b>	6F	FL073	30	15	76,39	74,79	83,0	62	-	72	84	12,0	2,46
		<b>PC8M-32S-62</b>	<b>08M62032</b>	6F	FL076	32	15	81,49	79,89	87,0	65	-	72	84	12,0	2,77
		<b>PC8M-34S-62</b>	<b>08M62034</b>	6F	FL066	34	15	86,58	84,98	91,0	70	-	72	84	12,0	3,11
		<b>PC8M-36S-62</b>	<b>08M62036</b>	6F	FL068	36	15	91,67	90,07	97,0	75	-	72	84	12,0	3,46
		<b>PC8M-38S-62</b>	<b>08M62038</b>	6F	FL070	38	15	96,77	95,17	102,0	75	-	72	84	12,0	3,84
		<b>TL PC8M-40S-62</b>	<b>0862040</b>	3F	FL077	40	2012	101,86	100,26	106,0	-	-	72	-	-	3,66
		<b>TL PC8M-45S-62</b>	<b>0862045</b>	3F	FL075	45	2012	114,59	112,99	120,0	-	-	72	-	-	4,78
		<b>TL PC8M-48S-62</b>	<b>0862048</b>	3F	FL078	48	2517	122,23	120,63	128,0	-	-	72	-	-	5,19
		<b>TL PC8M-50S-62</b>	<b>0862050</b>	3F	FL080	50	2517	127,32	125,72	135,0	-	-	72	-	-	5,61
		<b>TL PC8M-56S-62</b>	<b>0862056</b>	9WF	FL085	56	2517	142,60	141,00	150,0	-	111	72	45	13,5	7,76
		<b>TL PC8M-60S-62</b>	<b>0862060</b>	9WF	FL086	60	2517	152,79	151,19	158,0	-	121	72	45	13,5	8,83
<b>TL PC8M-64S-62</b>	<b>0862064</b>	9WF	FL090	64	2517	162,97	161,37	168,0	-	131	72	45	13,5	9,97		
Ghisa / Cast iron Grauguss / Fonte Hierro fundido	senza flangia / without flanges ohne Flanschen / sans flasques sin tapetas	<b>TL PC8M-75S-62</b>	<b>0862075</b>	4	-	75	3020	190,99	189,39	-	-	159	72	51	10,5	10,92
		<b>TL PC8M-80S-62</b>	<b>0862080</b>	4	-	80	3020	203,72	202,12	-	-	172	72	51	10,5	13,16
		<b>TL PC8M-90S-62</b>	<b>0862090</b>	4	-	90	3020	229,18	227,58	-	-	197	72	51	10,5	16,59
		<b>TL PC8M-112S-62</b>	<b>0862112</b>	9W	-	112	3020	285,21	283,61	-	150	253	72	51	10,5	22,05
		<b>TL PC8M-140S-62</b>	<b>0862140</b>	9W	-	140	3525	356,51	354,91	-	198	324	72	65	3,5	30,17
		<b>TL PC8M-168S-62</b>	<b>0862168</b>	9A	-	168	3525	427,81	426,21	-	198	396	72	65	3,5	39,34
		<b>TL PC8M-192S-62</b>	<b>0862192</b>	9A	-	192	3525	488,92	487,32	-	198	457	72	65	3,5	56,21

**PC14M-20**

Caratteristiche Features Merkmale Características	Codice Code symbol Fabriknummer Code symbole Numero de fabrica	Nostro codice Our code Unser Code Notre code Nuestro codigo	Tipo Type Typ Type Tipo	Codice flangia Flange code Bordscheiben-Code Code flasque Código brida	N. denti N. of teeth Zahnezahl N. bre de dents Cantidad de dientes	Foro d / Bussola. Bush d / Bore. Bohrung d / Buchse. Alesage d / Moyeu. Agujero d / Casquillo.	Dp	De	Df	Dm	Di	F	S	R	Peso Weight Gewicht Poids Peso Kg	
Acciaio / Steel / Stahl Acier / Acero	con flangia / with flanges mit Flanges / avec flasques / con tapetas	<b>TL 28-PC14M-20</b>	<b>1420028</b>	3F	FL153	28	2012	124,78	121,98	128,0	-	-	33	-	-	2,52
		<b>TL 30-PC14M-20</b>	<b>1420030</b>	3F	FL154	30	2012	133,69	130,89	138,0	-	-	33	-	-	2,98
		<b>TL 32-PC14M-20</b>	<b>1420032</b>	3F	FL160	32	2012	142,6	139,8	154,0	-	-	33	-	-	3,47
		<b>TL 34-PC14M-20</b>	<b>1420034</b>	8F	FL171	34	2517	151,52	148,72	160,0	117	-	33	45	12,0	4,34
		<b>TL 36-PC14M-20</b>	<b>1420036</b>	8F	FL168	36	2517	160,43	157,53	168,0	117	-	33	45	12,0	4,89
		<b>TL 38-PC14M-20</b>	<b>1420038</b>	8F	FL172	38	2517	169,34	166,54	183,0	117	-	33	45	12,0	5,48
		<b>TL 40-PC14M-20</b>	<b>1420040</b>	8F	FL174	40	2517	178,25	175,45	188,0	117	-	33	45	12,0	6,10
		<b>TL 44-PC14M-20</b>	<b>1420044</b>	8F	FL175	44	3020	196,08	193,28	211,0	144	-	33	51	18,0	7,89
		<b>TL 48-PC14M-20</b>	<b>1420048</b>	8F	FL180	48	3020	213,9	211,11	226,0	144	-	33	51	18,0	9,35
		<b>TL 50-PC14M-20</b>	<b>1420050</b>	8F	FL169	50	3020	222,82	220,02	240,0	144	-	33	51	18,0	9,49
<b>TL 56-PC14M-20</b>	<b>1420056</b>	7WF	FL182	56	3020	249,55	246,76	256,0	144	207	33	51	9,0	10,67		
Ghisa / Cast iron Grauguss / Fonte Hierro fundido	senza flangia / without flanges ohne Flanschen / sans flasques sin tapetas	<b>TL 60-PC14M-20</b>	<b>1420060</b>	7W	-	60	3020	267,38	264,58	-	159	224	33	51	9,0	12,66
		<b>TL 64-PC14M-20</b>	<b>1420064</b>	7W	-	64	3020	285,21	282,41	-	159	242	33	51	9,0	13,88
		<b>TL 72-PC14M-20</b>	<b>1420072</b>	7W	-	72	3020	320,86	318,06	-	159	278	33	51	9,0	16,53
		<b>TL 80-PC14M-20</b>	<b>1420080</b>	7W	-	80	3020	356,51	353,71	-	159	314	33	51	9,0	19,47
		<b>TL 90-PC14M-20</b>	<b>1420090</b>	7A	-	90	3020	401,07	398,27	-	159	360	33	51	9,0	23,49
		<b>TL 112-PC14M-20</b>	<b>1420112</b>	7A	-	112	3020	499,11	496,31	-	159	456	33	51	9,0	34,22
		<b>TL 140-PC14M-20</b>	<b>1420140</b>	7A	-	140	3020	623,89	621,09	-	159	581	33	51	9,0	43,26

**PC14M-37**

Caratteristiche Features Merkmal Características	Codice Code symbol Fabriknummer Code symbole Numero de fabrica	Nostro codice Our code Unser Code Notre code Nuestro codigo	Tipo Type Typ Type Tipo	Codice flangia Flange code Bordscheiben-Code Code flasque Código brida	N. denti N. of teeth Zahnezahl N. bre de dents Cantidad de dientes	Foro d / Bussola. Bush d / Bore. Bohrung d / Buchse. Alesage d / Moyeu. Agujero d / Casquillo.	Dp	De	Df	Dm	Di	F	S	R	Peso Weight Poids Peso Kg	
Acciaio / Steel / Stahl Acier / Acero	con flangia / with flanges mit Flanges / avec flasques / con tapetas	<b>TL 28-PC14M-37</b>	<b>1437028</b>	5F2	FL153	28	2012	124,78	121,98	128,0	-	88	51	32	19,0	3,70
		<b>TL 30-PC14M-37</b>	<b>1437030</b>	4F	FL154	30	2517	133,69	130,89	138,0	-	98	51	45	3,0	3,86
		<b>TL 32-PC14M-37</b>	<b>1437032</b>	4F	FL160	32	2517	142,6	139,8	154,0	-	100	51	45	3,0	4,60
		<b>TL 34-PC14M-37</b>	<b>1437034</b>	4F	FL171	34	2517	151,52	148,72	160,0	-	109	51	45	3,0	5,34
		<b>TL 36-PC14M-37</b>	<b>1437036</b>	5F2	FL168	36	2517	160,43	157,53	168,0	-	117	51	45	6,0	6,12
		<b>TL 38-PC14M-37</b>	<b>1437038</b>	5F2	FL172	38	2517	169,34	166,54	183,0	-	126	51	45	6,0	6,96
		<b>TL 40-PC14M-37</b>	<b>1437040</b>	5F2	FL174	40	2517	178,25	175,45	188,0	-	135	51	45	6,0	7,83
		<b>TL 44-PC14M-37</b>	<b>1437044</b>	3F	FL175	44	3020	196,08	193,28	211,0	-	51	-	-	-	9,73
		<b>TL 48-PC14M-37</b>	<b>1437048</b>	3F	FL180	48	3020	213,9	211,11	226,0	-	51	-	-	-	12,00
Ghisa / Cast Iron Grauguss / Fonte Hierro fundido	senza flangia / without flanges ohne Flanschen / sans flasques sin tapetas	<b>TL 50-PC14M-37</b>	<b>1437050</b>	3F	FL169	50	3020	222,82	220,02	240,0	-	51	-	-	-	12,36
		<b>TL 56-PC14M-37</b>	<b>1437056</b>	9WF	FL182	56	3020	249,55	246,76	256,0	144	207	51	51	-	14,18
		<b>TL 60-PC14M-37</b>	<b>1437060</b>	9W	-	60	3020	267,38	264,58	-	159	224	51	51	-	16,54
		<b>TL 64-PC14M-37</b>	<b>1437064</b>	9W	-	64	3020	285,21	282,41	-	159	242	51	51	-	18,42
		<b>TL 72-PC14M-37</b>	<b>1437072</b>	9W	-	72	3020	320,86	318,06	-	159	278	51	51	-	22,52
		<b>TL 80-PC14M-37</b>	<b>1437080</b>	9W	-	80	3020	356,51	353,71	-	159	314	51	51	-	27,06
		<b>TL 90-PC14M-37</b>	<b>1437090</b>	9A	-	90	3020	401,07	398,27	-	159	360	51	51	-	33,27
		<b>TL 112-PC14M-37</b>	<b>1437112</b>	9A	-	112	3020	499,11	496,31	-	159	456	51	51	-	49,85
		<b>TL 140-PC14M-37</b>	<b>1437140</b>	7A	-	140	3525	623,89	621,09	-	206	581	51	65	7,0	79,63
		<b>TL 168-PC14M-37</b>	<b>1437168</b>	7A	-	168	3525	748,66	745,87	-	206	706	51	65	7,0	94,25
	<b>TL 192-PC14M-37</b>	<b>1437192</b>	7A	-	192	4030	855,61	852,82	-	215	812	51	76	12,5	122,63	

**PC14M-68**

Caratteristiche Features Merkmal Características	Codice Code symbol Fabriknummer Code symbole Numero de fabrica	Nostro codice Our code Unser Code Notre code Nuestro codigo	Tipo Type Typ Type Tipo	Codice flangia Flange code Bordscheiben-Code Code flasque Código brida	N. denti N. of teeth Zahnezahl N. bre de dents Cantidad de dientes	Foro d / Bussola. Bush d / Bore. Bohrung d / Buchse. Alesage d / Moyeu. Agujero d / Casquillo.	Dp	De	Df	Dm	Di	F	S	R	Peso Weight Poids Peso Kg	
Acciaio / Steel / Stahl Acier / Acero	con flangia / with flanges mit Flanges / avec flasques / con tapetas	<b>34-PC14M-68</b>	<b>14M68034</b>	6F	FL171	34	32	151,52	148,72	160,0	131	-	84	104	20,0	13,01
		<b>36-PC14M-68</b>	<b>14M68036</b>	6F	FL168	36	32	160,43	157,53	168,0	131	-	84	104	20,0	14,40
		<b>38-PC14M-68</b>	<b>14M68038</b>	6F	FL172	38	32	169,34	166,54	183,0	141	-	84	104	20,0	16,15
		<b>40-PC14M-68</b>	<b>14M68040</b>	6F	FL174	40	32	178,25	175,45	188,0	155	-	84	104	20,0	18,28
		<b>TL 44-PC14M-68</b>	<b>1468044</b>	4F	FL175	44	3020	196,08	193,28	211,0	-	153	84	51	16,5	14,03
		<b>TL 48-PC14M-68</b>	<b>1468048</b>	5F2	FL180	48	3020	213,9	211,11	226,0	-	171	84	51	33,0	15,11
Ghisa / Cast Iron Grauguss / Fonte Hierro fundido	senza flangia / without flanges ohne Flanschen / sans flasques sin tapetas	<b>TL 50-PC14M-68</b>	<b>1468050</b>	4F	FL169	50	3525	222,82	220,02	240,0	-	180	84	65	9,5	16,16
		<b>TL 56-PC14M-68</b>	<b>1468056</b>	4F	FL182	56	3525	249,55	246,76	256,0	-	207	84	65	9,5	21,06
		<b>TL 60-PC14M-68</b>	<b>1468060</b>	4	-	60	3525	267,38	264,58	-	-	224	84	65	9,5	24,68
		<b>TL 64-PC14M-68</b>	<b>1468064</b>	4	-	64	3525	285,21	282,41	-	-	242	84	65	9,5	28,48
		<b>TL 72-PC14M-68</b>	<b>1468072</b>	9W	-	72	3525	320,86	318,06	-	178	278	84	65	9,5	37,28
		<b>TL 80-PC14M-68</b>	<b>1468080</b>	9W	-	80	3525	356,51	353,71	-	178	314	84	65	9,5	44,76
		<b>TL 90-PC14M-68</b>	<b>1468090</b>	9A	-	90	3525	401,07	398,27	-	178	360	84	65	9,5	54,99
		<b>TL 112-PC14M-68</b>	<b>1468112</b>	9A	-	112	3525	499,11	496,31	-	178	456	84	65	9,5	82,31
		<b>TL 140-PC14M-68</b>	<b>1468140</b>	9A	-	140	3525	623,89	621,09	-	206	581	84	65	9,5	107,81
		<b>TL 168-PC14M-68</b>	<b>1468168</b>	9A	-	168	3525	748,66	745,87	-	206	706	84	65	9,5	151,57
		<b>TL 192-PC14M-68</b>	<b>1468192</b>	9A	-	192	4030	855,61	852,82	-	215	812	84	76	4,0	195,32

**Pulegge dentate POLY CHAIN® GT®**  
**POLY CHAIN® GT® Timing belt pulleys / POLY CHAIN® GT® Zahnriemenscheiben**  
**Poulies dentées POLY CHAIN® GT® / Poleas dentadas POLY CHAIN® GT®**



**PC14M-90**

Caratteristiche Features Merkmale Características Características		Codice Code symbol Fabriknummer Code symbole Numero de fabrica	Nostro codice Our code Unser Code Notre code Nuestro codigo	Tipo Type Typ Tipo	Codice flangia Flange code Bordscheiben-Code Code flasque Código brida	Foro d / Bussola. Bush d / Bore. Bohrung d / Buchse. Alesage d / Moyeu. Agujero d / Casquillo	N. denti N. of teeth Zahnezahl N. bre de dents Cantidad de dientes	Dp	De	Df	Dm	Di	F	S	R	Peso Weight Poids Peso Kg
Acciaio / Steel / Stahl / Acero	con flangia / with flanges mit Flanges / avec flasques con tapetas	<b>36-PC14M-90</b>	<b>14M90036</b>	6F	FL168	32	36	160,43	157,53	168,0	131	-	106	136	30,0	18,52
		<b>38-PC14M-90</b>	<b>14M90038</b>	6F	FL172	32	38	169,34	166,54	183,0	141	-	106	136	30,0	21,25
		<b>40-PC14M-90</b>	<b>14M90040</b>	6F	FL174	32	40	178,25	175,45	188,0	155	-	106	136	30,0	23,75
		<b>44-PC14M-90</b>	<b>14M90044</b>	6F	FL175	32	44	196,08	193,28	211,0	167	-	106	136	30,0	28,82
		<b>TL 48-PC14M-90</b>	<b>1490048</b>	4F	FL180	3525	48	213,9	211,11	226,0	-	171	106	66	20,0	17,84
		<b>TL 50-PC14M-90</b>	<b>1490050</b>	4F	FL169	3525	50	222,82	220,02	240,0	-	180	106	66	20,0	18,32
Ghisa / Cast iron Grauguss / Fonte Hierro fundido	senza flangia / without flanges ohne Flanschen / sans flasques sin tapetas	<b>TL 56-PC14M-90</b>	<b>1490056</b>	4F	FL182	3525	56	249,55	246,76	256,0	-	207	106	66	20,0	23,54
		<b>TL 60-PC14M-90</b>	<b>1490060</b>	4	-	3525	60	267,38	264,58	-	-	224	106	66	20,0	27,42
		<b>TL 64-PC14M-90</b>	<b>1490064</b>	4	-	3525	64	285,21	282,41	-	-	242	106	66	20,0	31,45
		<b>TL 72-PC14M-90</b>	<b>1490072</b>	9W	-	3525	72	320,86	318,06	-	178	278	106	66	20,0	47,05
		<b>TL 80-PC14M-90</b>	<b>1490080</b>	9W	-	4030	80	356,51	353,71	-	215	314	106	76	15,0	58,85
		<b>TL 90-PC14M-90</b>	<b>1490090</b>	9W	-	4030	90	401,07	398,27	-	215	360	106	76	15,0	71,76
		<b>TL 112-PC14M-90</b>	<b>1490112</b>	9A	-	4535	112	499,11	496,31	-	215	456	106	90	8,0	105,81
		<b>TL 140-PC14M-90</b>	<b>1490140</b>	9A	-	4535	140	623,89	621,09	-	215	581	106	90	8,0	135,46
		<b>TL 168-PC14M-90</b>	<b>1490168</b>	9A	-	5040	168	748,66	745,87	-	267	708	106	102	2,0	193,77
		<b>TL 192-PC14M-90</b>	<b>1490192</b>	9A	-	5040	192	855,61	852,82	-	267	812	106	102	2,0	249,78

**PC14M-125**

Caratteristiche Features Merkmale Características Características		Codice Code symbol Fabriknummer Code symbole Numero de fabrica	Nostro codice Our code Unser Code Notre code Nuestro codigo	Tipo Type Typ Tipo	Codice flangia Flange code Bordscheiben-Code Code flasque Código brida	N. denti N. of teeth Zahnezahl N. bre de dents Cantidad de dientes	Foro d / Bussola. Bush d / Bore. Bohrung d / Buchse. Alesage d / Moyeu. Agujero d / Casquillo	Dp	De	Df	Dm	Di	F	S	R	Peso Weight Poids Peso Kg
Acciaio / Steel / Stahl / Acero	con flangia / with flanges mit Flanges / avec flasques con tapetas	<b>38-PC14M-125</b>	<b>14M125038</b>	6F	FL172	38	32	169,34	166,54	183,0	141	-	141	161	20,0	25,75
		<b>40-PC14M-125</b>	<b>14M125040</b>	6F	FL174	40	32	178,25	175,45	188,0	155	-	141	161	20,0	28,73
		<b>44-PC14M-125</b>	<b>14M125044</b>	6F	FL175	44	32	196,08	193,28	211,0	167	-	141	161	20,0	35,00
		<b>48-PC14M-125</b>	<b>14M125048</b>	6F	FL180	48	32	213,9	211,11	226,0	185	-	141	161	20,0	41,93
Ghisa / Cast iron Grauguss / Fonte Hierro fundido	senza flangia / without flanges ohne Flanschen / sans flasques sin tapetas	<b>TL 50-PC14M-125</b>	<b>14125050</b>	4F	FL169	50	3525	222,82	220,02	240,0	-	180	141	65	38,0	21,42
		<b>TL 56-PC14M-125</b>	<b>14125056</b>	4F	FL182	56	3525	249,55	246,76	256,0	-	207	141	65	38,0	27,00
		<b>TL 60-PC14M-125</b>	<b>14125060</b>	4	-	60	4030	267,38	264,58	-	-	224	141	76	32,5	32,33
		<b>TL 64-PC14M-125</b>	<b>14125064</b>	4	-	64	4030	285,21	282,41	-	-	242	141	76	32,5	37,12
		<b>TL 72-PC14M-125</b>	<b>14125072</b>	9W	-	72	4030	320,86	318,06	-	215	278	141	76	32,5	65,74
		<b>TL 80-PC14M-125</b>	<b>14125080</b>	9W	-	80	4030	356,51	353,71	-	215	314	141	76	32,5	78,28
		<b>TL 90-PC14M-125</b>	<b>14125090</b>	9W	-	90	4030	401,07	398,27	-	215	360	141	76	32,5	95,46
		<b>TL 112-PC14M-125</b>	<b>14125112</b>	9A	-	112	4535	499,11	496,31	-	215	581	141	89	26,0	98,56
		<b>TL 140-PC14M-125</b>	<b>14125140</b>	9A	-	140	4535	623,89	621,09	-	215	581	141	89	26,0	180,19
		<b>TL 168-PC14M-125</b>	<b>14125168</b>	9A	-	168	5040	748,66	745,87	-	267	706	141	102	19,5	258,53
		<b>TL 192-PC14M-125</b>	<b>14125192</b>	9A	-	192	5040	855,61	852,82	-	267	812	141	102	19,5	332,26

Codici delle flange Codes of flanges Codes der Bordscheiben Codes des flasques Códigos de las bridas	Tipo di puleggia (Profilo della dentatura) / Type of pulley (Toothing profile) Riemenscheibentyp (Verzahnungsprofil) / Type de poulie (Profil de denture) Tipo de polea (Perfil de los dientes)															
	MXL	XL	L	H	XH	XXH	3M	5M	8M	14M	PC GT 8M	PC GT 14M	T2.5	T5 ST5	T10 ST10	T20
10		FL001	FL050				FL501								FL003	FL007
11		FL001	FL050												FL001	FL009
12		FL002	FL052				FL502	FL014					FL501	FL001	FL013	
13		FL002	FL083										FL501	FL002	FL012	
14	F501A	FL004	FL054	FL059			FL503	FL002					FL502	FL002	FL011	
15		FL004	FL055	FL060			FL516	FL004					FL502	FL004	FL016	
16	FL502	FL005	FL056	FL061			FL504	FL004					FL503	FL005	FL018	
17		FL006	FL057	FL062									FL503	FL005	FL020	
18	FL503	FL007	FL058	FL063	FL155	FL163	FL505	FL006	F055A				FL504	FL006	FL021	FL075
19		FL007	FL059	FL064	FL156	FL164			F056A				FL505	FL008	FL024	
20	FL503	FL009	FL060	FL076	FL157	FL165	FL517	FL008	F052A				FL505	FL008	FL024	FL080
21		FL009	FL061	FL066	FL158	FL167	FL518	FL009					FL505	FL009	FL026	
22	FL504	FL010	FL062	FL067	FL159	FL169	FL518	FL015	FL053		FL053		FL512	FL009	FL027	FL085
23		FL013	FL063	FL068					F059A				FL512	FL010	FL027	
24	FL505	FL012	FL063	FL070	FL161	FL173	FL518	FL013	FL069				FL512	FL013	FL029	FL086
25		FL012	FL064	FL071	FL162						FL061		FL506	FL012	FL029	FL090
26		FL011	FL065	FL072	FL163	FL178	FL508	FL012	FL061				FL507	FL012	FL031	
27		FL011	FL065	FL074	FL164				F062A				FL507	FL011	FL032	
28	FL506	FL016	FL066	FL075	FL165		FL509	FL011	FL079	FL153	FL079	FL153	FL507	FL011	FL033	
29		FL016		FL075									FL507	FL016		
30	FL506	FL018	FL068	FL078	FL167		FL509	FL016	FL073	FL154	FL073	FL154	FL508	FL016	FL035	FL100
31	F506A															
32	FL507	FL020	FL070	FL080	FL169		FL510	FL018	FL076	FL160	FL076	FL160	FL509	FL018	FL038	
33			FL071	FL081									FL509			
34		FL022	FL072	FL081	FL170			FL020	FL066	FL166	FL066	FL171	FL509	FL021	FL072	
35		FL022	FL072	FL085					F067A				FL509	FL022		
36	FL508	FL023	FL074	FL085			FL519	FL021	FL068	FL168	FL068	FL168	FL510	FL023	FL043	
37									F168A				FL510	FL023		
38		FL024		FL086				FL024	FL070	FL172	FL070	FL172	FL510	FL024	FL078	
39		FL024						F024A								
40	FL509	FL026	FL078	FL090			FL513	FL025	FL077	FL162	FL077	FL174	FL511	FL024	FL047	
41		FL026														
42	FL509	FL027	FL080	FL094									FL511	FL026		
43		FL027														
44	FL510	FL027	FL081	FL095			FL520	FL027	FL075	FL175		FL175	FL513	FL027		
45			FL081	FL096					F075A		FL075			FL027	FL085	
46									F076A					FL029		
47									F180A							
48		FL029	FL085	FL0100				FL029	FL078	FL180	FL078	FL180	FL513	FL029	FL086	
50									F182A	FL080	FL169	FL514	FL031			
56		FL035						FL033	FL085	FL182	FL085	FL182				
60	F513A	FL038							F086A		FL086		FL515	FL038	FL100	
64	F514A							FL038	FL090	FL184	FL090					
72		F043A						FL043	FL097							
80									F100A							

 Numero dei denti della puleggia (Z) / Teeth number of pulley (Z)  
 Scheibenzähnezahl (Z) / Nombre de dents de la poulie (Z) / Número de dientes de la polea (Z)



**Dimensioni delle flange / Flange dimensions**  
**Bordscheiben-Abmessungen / Dimension de flasque / Dimensiones de las bridas**



**Dimensioni delle flange / Flange dimensions**  
**Bordscheiben-Abmessungen / Dimension de flasque**  
**Dimensiones de las bridas**

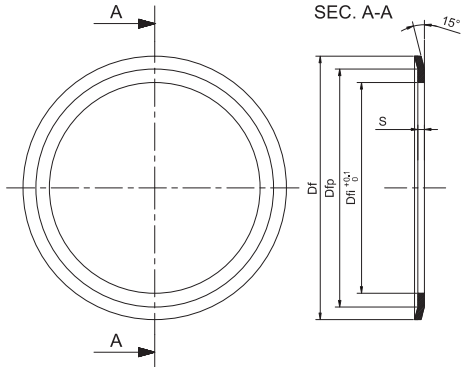

Codice flangia Flange code Bordscheiben-Code Code flasque Código brida	Dimensioni delle flange Flange dimensions Bordscheiben-Abmessungen Dimension de flasque Dimensiones de las bridas			
	Df	Dfi	Dfp	S
FL501	13,0	6,0	10,0	0,5
F501A	12,0	6,5	9,0	0,5
FL502	15,0	8,0	12,0	0,5
FL503	16,0	9,5	13,0	0,5
FL504	17,5	11,6	14,5	0,5
FL505	20,0	12,2	16,5	0,5
FL506	25,0	14,5	21,5	0,5
F506A	25,0	17,0	21,0	0,5
FL507	26,0	17,8	24,0	0,5
FL508	28,0	20,0	25,0	0,5
FL509	32,0	23,0	27,5	0,5
FL510	36,0	25,0	31,0	0,5
FL511	38,0	26,5	34,0	0,5
FL512	22,0	14,5	19,0	0,5
FL513	42,0	30,5	38,0	0,5
F513A	43,0	32,0	39,0	0,5
FL514	44,0	32,5	40,5	0,5
F514A	46,0	36,0	42,0	0,5
FL515	51,0	40,0	47,0	0,5
FL516	17,5	10,5	14,5	0,5
FL517	23,0	14,0	20,0	0,5
FL518	25,0	15,0	21,5	0,5
FL519	39,0	28,0	34,5	0,5
FL520	48,0	37,0	43,5	0,5

Codice flangia Flange code Bordscheiben-Code Code flasque Código brida	Dimensioni delle flange Flange dimensions Bordscheiben-Abmessungen Dimension de flasque Dimensiones de las bridas			
	Df	Dfi	Dfp	S
FL001	23,0	12,5	18,0	1,0
FL002	25,0	15,0	21,5	1,0
FL003	19,5	12,0	17,5	1,0
FL004	28,0	17,8	24,0	1,0
FL005	32,0	20,0	26,0	1,0
FL006	32,0	23,0	27,5	1,0
FL007	35,0	23,0	30,5	1,0
FL008	36,0	25,0	31,0	1,0
FL009	38,0	26,5	34,0	1,0
FL010	41,0	30,0	36,0	1,0
FL011	48,0	37,0	43,5	1,0
FL012	44,0	32,5	40,5	1,0
FL013	42,0	30,5	38,0	1,0
FL014	23,0	14,0	20,0	1,0
FL015	39,0	28,0	34,5	1,0
FL016	51,0	40,0	47,0	1,0
FL018	54,0	43,0	50,5	1,0
FL020	57,0	47,0	51,5	1,0
FL021	60,0	47,0	57,0	1,0
FL022	61,0	49,0	56,5	1,0
FL023	64,0	47,0	57,0	1,0
FL024	66,5	52,0	63,0	1,0
F024A	66,0	54,0	62,0	1,0
FL025	71,0	56,0	64,0	1,0
FL026	70,0	53,0	66,5	1,0
FL027	75,0	60,0	68,5	1,0
FL029	83,0	68,0	78,0	1,0
FL031	87,0	72,0	82,5	1,0
FL032	91,0	76,0	85,5	1,0
FL033	93,0	80,0	89,0	1,0
FL035	97,0	83,0	93,8	1,0
FL038	106,0	90,0	101,0	1,0
FL043	119,0	103,0	113,5	1,0
F043A	124,0	108,0	117,0	1,0
FL047	131,0	115,0	125,5	1,0

Codice flangia Flange code Bordscheiben-Code Code flasque Código brida	Dimensioni delle flange Flange dimensions Bordscheiben-Abmessungen Dimension de flasque Dimensiones de las bridas			
	Df	Dfi	Dfp	S
FL050	37,0	23,0	33,0	1,5
FL051	39,0	28,0	34,5	1,5
FL052	43,0	31,0	39,0	1,5
F052A	57,0	40,0	51,0	1,5
FL053	60,0	47,0	57,0	1,5
FL054	48,0	37,0	42,0	1,5
FL055	51,0	38,5	45,0	1,5
F055A	51,0	37,5	46,0	1,5
FL056	54,0	43,0	48,0	1,5
F056A	54,0	40,0	48,0	1,5
FL057	57,0	46,0	51,0	1,5
FL058	60,0	48,0	54,2	1,5
FL059	64,0	47,0	57,0	1,5
F059A	65,0	49,0	59,0	1,5
FL060	66,5	53,0	60,2	1,5
FL061	70,0	53,0	64,0	1,5
FL062	75,0	57,0	68,0	1,5
F062A	76,0	56,0	68,5	1,5
FL063	79,0	60,0	72,5	1,5
FL064	82,5	64,0	76,0	1,5
FL065	86,0	68,0	81,5	1,5
FL066	91,0	73,0	86,0	1,5
FL067	94,0	76,0	88,0	1,5
F067A	96,0	78,0	89,0	1,5
FL068	97,0	79,0	92,0	1,5
FL069	66,0	52,0	61,5	1,5
FL070	102,0	82,5	97,0	1,5
FL071	106,0	86,0	100,0	1,5
FL072	112,0	91,0	105,5	1,5
FL073	83,0	68,0	76,5	1,5
FL074	115,0	94,0	109,0	1,5
FL075	120,0	99,5	112,5	1,5
F075A	120,0	101,0	114,0	1,5
FL076	87,0	72,0	82,5	1,5
F076A	124,0	104,0	117,0	1,5
FL077	106,0	90,0	101,0	1,5
FL078	128,0	107,0	121,0	1,5
FL079	75,0	60,0	70,5	1,5
FL080	135,0	115,0	128,5	1,5
FL081	142,0	120,0	137,0	1,5
FL082	82,5	67,0	76,0	1,5
FL083	44,0	32,5	40,5	1,5
FL085	150,0	130,0	145,0	1,5
FL086	158,0	138,5	153,0	1,5
F086A	159,0	140,0	153,0	1,5
FL090	168,0	148,0	161,0	1,5
FL094	180,0	154,0	174,0	1,5
FL095	184,0	162,0	177,0	1,5
FL096	192,0	165,0	181,5	1,5
FL097	192,0	173,0	187,0	1,5
FL100	200,0	180,0	193,0	1,5
F100A	212,0	190,0	204,0	1,5

Codice flangia Flange code Bordscheiben-Code Code flasque Código brida	Dimensioni delle flange Flange dimensions Bordscheiben-Abmessungen Dimension de flasque Dimensiones de las bridas			
	Df	Dfi	Dfp	S
FL153	128,0	107,0	124,0	2,5
FL154	138,0	112,0	131,0	2,5
FL155	140,0	107,0	125,0	2,5
FL156	146,0	107,0	133,0	2,5
FL157	155,0	107,0	139,0	2,5
FL158	160,0	120,0	148,0	2,5
FL159	170,0	120,0	153,0	2,5
FL160	154,0	122,0	142,0	2,5
FL161	184,0	135,0	168,0	2,5
FL162	188,0	150,0	176,0	2,5
FL163	198,0	150,0	180,0	2,5
FL164	205,0	160,0	189,0	2,5
FL165	212,0	162,0	200,0	2,5
FL166	160,0	130,0	150,0	2,5
FL167	227,0	176,0	210,0	2,5
FL168	168,0	135,0	162,0	2,5
F168A	180,0	126,0	165,0	2,5
FL169	240,0	192,0	224,0	2,5
FL170	256,0	220,0	240,0	2,5
FL171	160,0	136,0	150,0	2,5
FL172	183,0	145,0	170,0	2,5
FL173	267,0	220,0	240,0	2,5
FL174	188,0	160,0	177,0	2,5
FL175	211,0	173,0	198,0	2,5
FL177	297,0	249,0	280,0	2,5
FL178	290,0	230,0	260,0	2,5
FL180	226,0	190,0	214,0	2,5
F180A	226,0	185,0	208,0	2,5
FL182	256,0	225,0	247,0	2,5
F182A	265,0	205,0	230,0	2,5
FL184	296,0	260,0	287,0	2,5

**Informazioni tecniche**  
**Technical information**  
**Technische Informationen**  
**Informations techniques**  
**Información técnica**

Materiale S235JR  
Material S235JR  
Werkstoff S235JR  
Matière S235JR  
Material S235JR

Sbavate e senza difetti sulla superficie  
Deburred and without defect on surface

Entgratet und mit  
mängelfreier Oberfläche

Ébavurées et sans défaut sur la surface  
Desbarbado y sin defecto en la superficie