

Forcelle ed accessori di complemento Clevises and complementary accessories

TIPO TYPE

Pag.

FK	111-112
FK..CN	113
FT	114
CL	115
CL..CN	115
PC	116
PCB	116
PM	117
PMB	117
PS	118
PS..CN	118
PC-R	119
PC-C	119
PM-S	120
PM-K	120
SE	121





Forcelle con foro filettato (DIN 71752 - ISO 8140 CETOP)

Clevises with threaded hole (DIN 71752 - ISO 8140 CETOP)

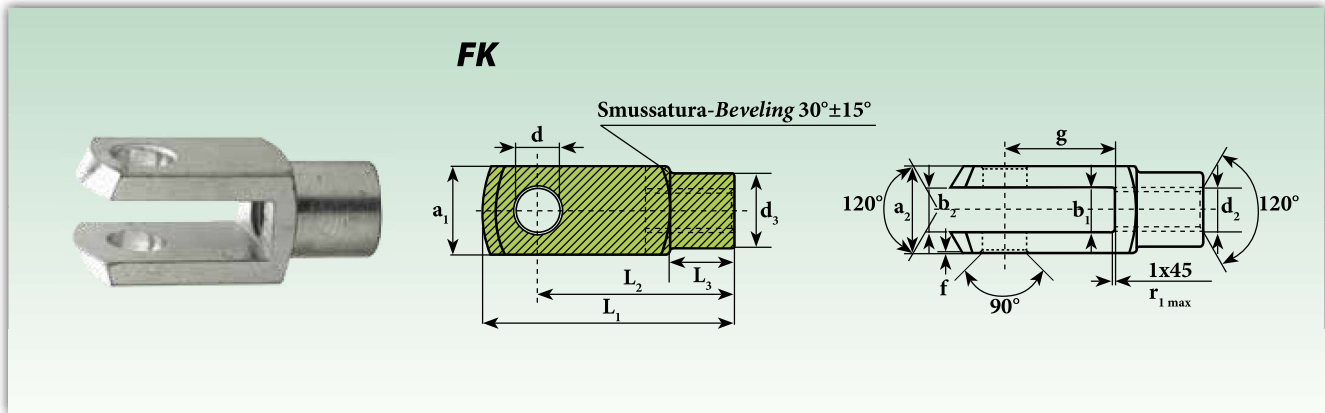

Sigla ¹⁾ Designation ¹⁾	Dimensioni mm Dimensions mm													Peso Weight
	d H9	d ₂ 6H	d ₃ ±0,3	a ₁ h11	a ₂ +0,30 -0,16	b ₁ B13	b ₂	f ±0,2	g ±0,5	L ₁ ±0,5	L ₂	L ₃ ±0,3	r _{1 max} ±0,5	≈ Kg
FK 4X8	4	M4 X 0,7	8	8	8	4	4 ³⁾	0,5	8	21	16 ⁵⁾	6	0,5	0,005
FK 4X16	4	M4 X 0,7	8	8	8	4	4 ³⁾	0,5	16	29	24 ⁵⁾	6	0,5	0,007
FK 5X10	5	M5 X 0,8	9	10	10	5	5 ³⁾	0,5	10	26	20 ⁵⁾	7,5	0,5	0,009
FK 5X20	5	M5 X 0,8	9	10	10	5	5 ³⁾	0,5	20	36	30 ⁵⁾	7,5	0,5	0,013
FK 6X12	6	M6 X 1,0	10	12	12	6	6 ³⁾	0,5	12	31	24 ⁵⁾	9	0,5	0,015
FK 6X24	6	M6 X 1,0	10	12	12	6	6 ³⁾	0,5	24	43	36 ⁶⁾	9	0,5	0,021
FK 8X16	8	M8 X 1,25	14	16	16	8	8 ³⁾	0,5	16	42	32 ⁶⁾	12	0,5	0,037
FK 8X16FG	8	M8 X 1,0	14	16	16	8	8 ³⁾	0,5	16	42	32 ⁶⁾	12	0,5	0,037
FK 8X32	8	M8 X 1,25	14	16	16	8	8 ³⁾	0,5	32	58	48 ⁶⁾	12	0,5	0,054
FK 8X32FG	8	M8 X 1,0	14	16	16	8	8 ³⁾	0,5	32	58	48 ⁶⁾	12	0,5	0,054
FK 10X20	10	M10 X 1,5	18	20	20	10	10 ³⁾	0,5	20	52	40 ⁶⁾	15	0,5	0,074
FK 10X20FG	10	M10 X 1,25	18	20	20	10	10 ³⁾	0,5	20	52	40 ⁶⁾	15	0,5	0,074
FK 10X40	10	M10 X 1,5	18	20	20	10	10 ⁴⁾	0,5	40	72	60 ⁶⁾	15	0,5	0,116
FK 10X40FG	10	M10 X 1,25	18	20	20	10	10 ⁴⁾	0,5	40	72	60 ⁶⁾	15	0,5	0,116
FK 12X24	12	M12 X 1,75	20	24	24	12	12 ⁴⁾	0,5	24	62	48 ⁶⁾	18	0,5	0,121
FK 12X24FG	12	M12 X 1,25	20	24	24	12	12 ⁴⁾	0,5	24	62	48 ⁶⁾	18	0,5	0,121
FK 12X48	12	M12 X 1,75	20	24	24	12	12 ⁴⁾	0,5	48	86	72 ⁶⁾	18	0,5	0,175
FK 12X48FG	12	M12 X 1,25	20	24	24	12	12 ⁴⁾	0,5	48	86	72 ⁶⁾	18	0,5	0,175
FK 14X28	14	M14 X 2,0	24	27	27	14	14 ⁴⁾	1	28	72	56 ⁶⁾	22,5	1	0,178
FK 14X28FG	14	M14 X 1,5	24	27	27	14	14 ⁴⁾	1	28	72	56 ⁶⁾	22,5	1	0,178
FK 14X56	14	M14 X 2,0	24	27	27	14	14 ⁴⁾	1	56	101	85 ⁶⁾	22,5	1	0,258
FK 14X56FG	14	M14 X 1,5	24	27	27	14	14 ⁴⁾	1	56	101	85 ⁶⁾	22,5	1	0,258
FK 16X32	16	M16 X 2,0	26	32	32	16	16 ⁴⁾	1	32	83	64 ⁶⁾	24	1	0,282
FK 16X32FG	16	M16 X 1,5	26	32	32	16	16 ⁴⁾	1	32	83	64 ⁶⁾	24	1	0,282
FK 16X64	16	M16 X 2,0	26	32	32	16	16 ⁴⁾	1	64	115	96 ⁶⁾	24	1	0,411
FK 16X64FG	16	M16 X 1,5	26	32	32	16	16 ⁴⁾	1	64	115	96 ⁶⁾	24	1	0,411
FK 18X36	18	M18 X 2,5	30	36	36	18	18 ⁴⁾	1	36	94	72 ⁶⁾	27	1,5	0,390
FK 18X36FG	18	M18 X 1,5	30	36	36	18	18 ⁴⁾	1	36	94	72 ⁶⁾	27	1,5	0,390

¹⁾ Per filettatura a sinistra aggiungere il suffisso "L" (esempio: FKL..)

For left thread, suffix "L" is added (example: FKL..)

²⁾ Tipo con filetto CETOP thread type

³⁾ Tolleranza Tolerance B13: +0,33 ≈ +0,15

⁴⁾ Tolleranza Tolerance: +0,70 ≈ +0,15

⁵⁾ Tolleranza Tolerance: ± 0,3

⁶⁾ Tolleranza Tolerance: ± 0,4

FG= Passo fine Thin thread

Forcelle con foro filettato (DIN 71752 - ISO 8140 CETOP)

Clevises with threaded hole (DIN 71752 - ISO 8140 CETOP)

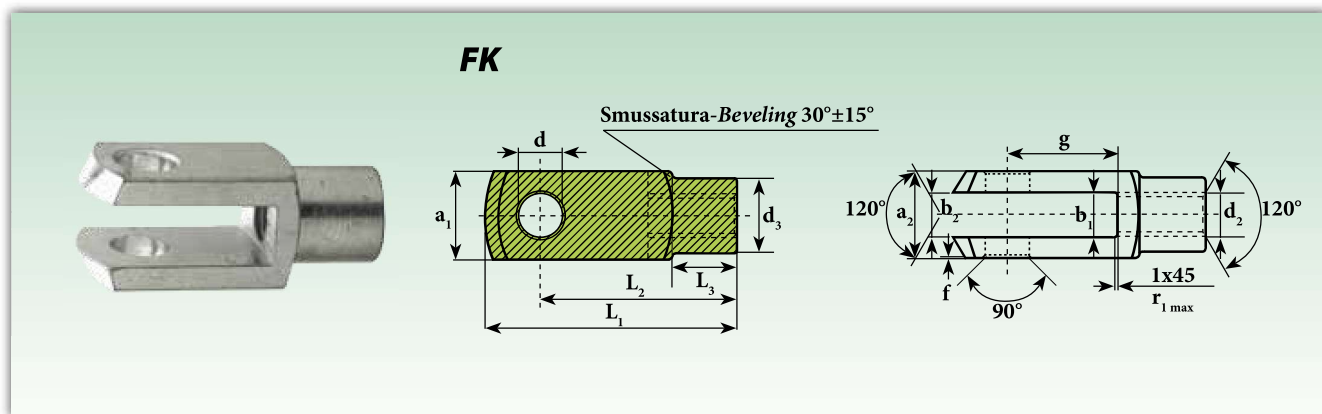

Sigla ¹⁾ Designation ¹⁾	Dimensioni mm Dimensions mm													Peso Weight ≈ Kg
	d H9	d ₂ 6H	d ₃ ±0,3	a ₁ h11	a ₂ +0,30 -0,16	b ₁ B13	b ₂	f ±0,2	g ±0,5	L ₁ ±0,5	L ₂	L ₃ ±0,3	r _{1max} ±0,5	
FK 20X40	20	M20 X 2,5	34	40	40	20	20 ⁴⁾	1	40	105	80 ⁶⁾	30	1,5	0,55
FK 20X40.1 ²⁾	20	M20 X 1,5	34	40	40	20	20 ⁴⁾	1	40	105	80 ⁶⁾	30	1,5	0,55
FK 20X80	20	M20 X 2,5	34	40	40	20	20 ⁴⁾	1	80	145	120 ⁶⁾	30	1,5	0,8
FK 20X80FG	20	M20 X 1,5	34	40	40	20	20 ⁴⁾	1	80	145	120 ⁶⁾	30	1,5	0,8
FK 25X50	25	M24 X 3,0	42	50	50	25	25 ⁴⁾	1,5	50	132	100 ⁶⁾	36	1,5	1,1
FK 25X50.1 ²⁾	25	M24 X 2,0	42	50	50	25	25 ⁴⁾	1,5	50	132	100 ⁶⁾	36	1,5	1,1
FK 28X56	28	M27 X 3,0	48	55	55	28	28 ⁴⁾	1,5	56	148	112 ⁶⁾	40	2	1,5
FK 28X56FG	28	M27 X 2,0	48	55	55	28	28 ⁴⁾	1,5	56	148	112 ⁶⁾	40	2	1,5
FK 30X54.1 ²⁾	30	M27 X 2,0	48	55	55	30	30 ⁴⁾	1,5	54	148	110 ⁶⁾	40	2	1,44
FK 30X60	30	M30 X 3,5	52	60	60	30	30 ⁴⁾	1,5	60	160	120 ⁶⁾	42	2	1,97
FK 30X60FG	30	M30 X 2,0	52	60	60	30	30 ⁴⁾	1,5	60	160	120 ⁶⁾	42	2	1,97
FK 35X54.1 ²⁾	35	M36 X 2,0	60	70	70	35	35 ⁴⁾	2	54	188	144 ⁶⁾	54	3	2,93
FK 35X72	35	M36 X 4,0	60	70	70	35	35 ⁴⁾	2	72	188	144 ⁶⁾	54	3	2,93
FK 35X72FG	35	M36 X 2,0	60	70	70	35	35 ⁴⁾	2	72	188	144 ⁶⁾	54	3	2,93
FK 36X72	36	M36 X 4,0	60	70	70	36	36 ⁴⁾	2	72	188	144 ⁶⁾	54	3	2,93
FK 36X72FG	36	M36 X 2,0	60	70	70	36	36 ⁴⁾	2	72	188	144 ⁶⁾	54	3	2,93
FK 40X84.1 ²⁾	40	M42 X 2,0	70	85	85	40	40 ⁴⁾	3	84	232	168 ⁶⁾	63,5	5	5,64
FK 42X84	42	M42 X 4,5	70	85	85	42	42 ⁴⁾	3	84	232	168 ⁶⁾	63,5	5	5,34
FK 42X84FG	42	M42 X 2,0	70	85	85	42	42 ⁴⁾	3	84	232	168 ⁶⁾	63,5	5	5,34
FK 50X96	50	M48 X 5,0	82	96	96	50	50 ⁴⁾	3	96	265	192 ⁶⁾	73	5	7,86
FK 50X96.1 ²⁾	50	M48 X 2,0	82	96	96	50	50 ⁴⁾	3	96	265	192 ⁶⁾	73	5	7,86

Su richiesta, disponibili in acciaio inox ed alluminio
Under request, stainless steel and aluminium available

¹⁾ Per filettatura a sinistra aggiungere il suffisso "L" (esempio: FKL..)

For left thread, suffix "L" is added (example: FKL..)

²⁾ Tipo con filetto CETOP thread type

³⁾ Tolleranza Tolerance B13: +0,33 ≈ +0,15

⁴⁾ Tolleranza Tolerance: +0,70 ≈ +0,15

⁵⁾ Tolleranza Tolerance: ± 0,3

⁶⁾ Tolleranza Tolerance: ± 0,4

FG= Passo fine Thin thread

Forcelle con foro filettato ex CNomo

Clevises with threaded hole ex CNomo

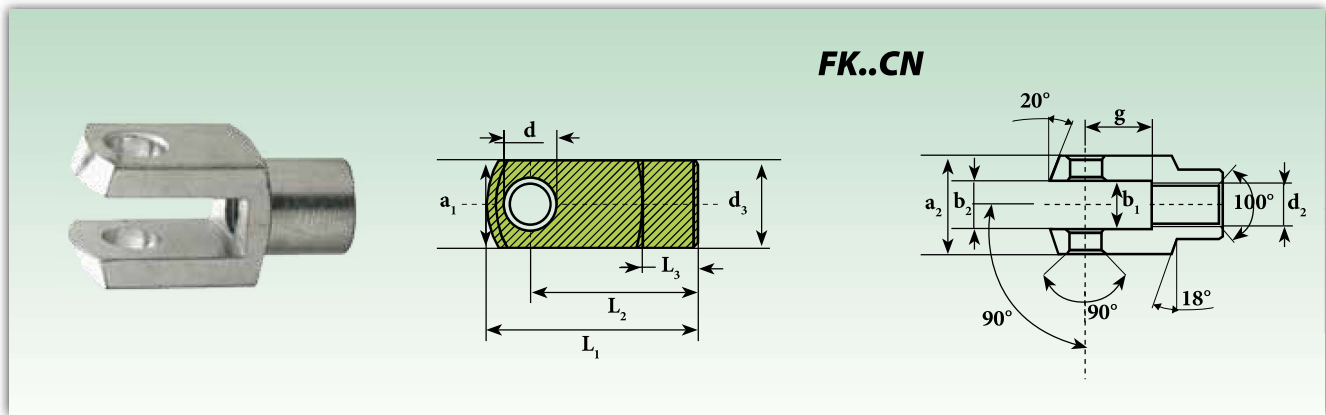

Sigla ¹⁾ Designation ¹⁾	Dimensioni mm Dimensions mm												Carico Ratings load	Peso Weight
	Alesaggio Bore	d H8	d ₂ 6H	d ₃ ±0,3	a ₁ h11	a ₂ h11	b ₁ H11	b ₂ H11	g ±0,5	L ₁ ±0,5	L ₂ ±0,3	L ₃ ±0,2	Statico C ₀ Static C ₀ KN	≈ Kg
FK8X16CN	32	8	M10X1,5	18	22	22	11	11	16	45	36	14	313,97	0,08
FK12X25CN	40-50	12	M16X1,5	26	26	36	18	18	25	64	51	17	513,76	0,21
FK16X33CN	63-80	16	M20X1,5	34	34	45	22	22	33	80	63	18,50	844,04	0,44
FK20X40CN	100-125	20	M27X2,0	42	42	63	30	30	40	105	85	30	1.480,12	0,91
FK25X40CN	160-200	25	M36X2,0	50	50	80	40	40	40	140	115	45	2.038,74	1,80

Su richiesta, disponibili in acciaio inox ed alluminio
Under request, stainless steel and aluminium available

¹⁾ Per filettatura a sinistra aggiungere il suffisso "L" (esempio: FKL..CN)
 For left thread, suffix "L" is added (example: FKL..CN)

Forcelle con gambo filettato (DIN 71752 - ISO 8140 CETOP)

Clevises with male thread (DIN 71752 - ISO 8140 CETOP)

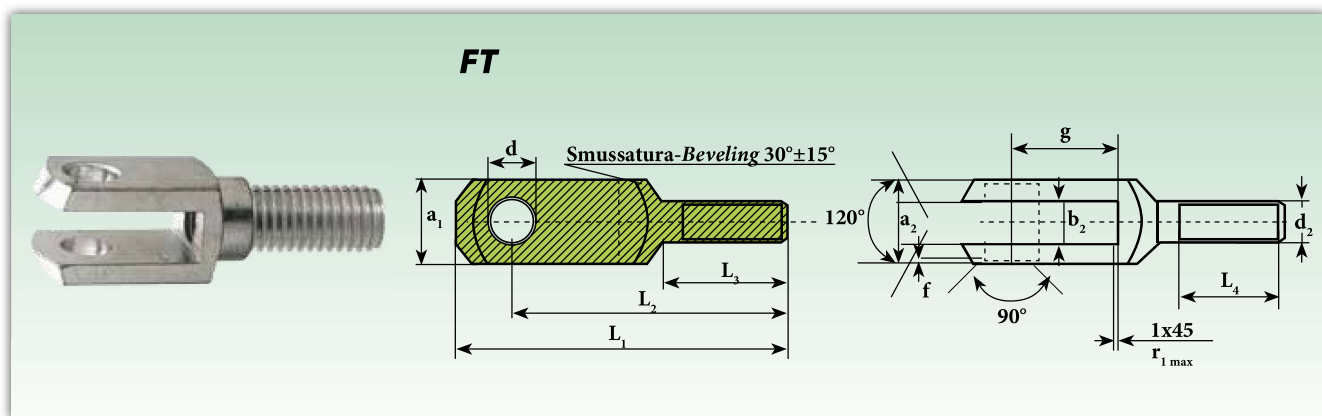

Sigla Designation	Dimensioni mm Dimensions mm												Peso Weight
	d H9	d ₂ 6g	a ₁ h11	a ₃ +0,50 -0,20	b ₂ +0,70 +0,15	f ±0,2	g ±0,5	L ₁ ±0,2	L ₂ ±0,4	L ₃ ±0,2	L ₄ min	r _{1 max} ±0,5	≈ Kg
FT 6X12	6	M6 X 1,0	12	12	6	0,5	12	44	37	20	15	0,8	0,015
FT 8X16	8	M8 X 1,25	16	16	8	0,5	16	57	47	25	20	0,8	0,036
FT 10X20	10	M10 X 1,5	20	20	10	0,5	20	69	57	30	25	0,8	0,068
FT 12X24	12	M12 X 1,75	24	24	12	0,5	24	82	68	35	30	0,8	0,122
FT 14X28	14	M14 X 2,0	27	27	14	1	28	94	78	40	35	1,2	0,171
FT 16X32	16	M16 X 2,0	32	32	16	1	32	108	89	45	40	1,2	0,282
FT 20X40	20	M20 X 2,5	40	40	20	1	40	134	109	55	50	1,5	0,550

Clips per forcelle

Spring pins for clevises



Sigla Designation	Dimensioni mm Dimensions mm							Peso Weight
	d h11	a	b	g	L ₁ ≈	L ₂ ≈	L ₃ ≈	≈ Kg
CL 4X8	4	9,5	11	8	19	15	4,5	0,0015
CL 4X16	4	9,5	11	16	26	23,5	4,5	0,0020
CL 5X10	5	12	13,5	10	23	19	5,5	0,0025
CL 5X20	5	12	13,5	20	33	29	5,5	0,0031
CL 6X12	6	14	16	12	28	23	6,5	0,0046
CL 6X24	6	14	16	24	40	35	6,5	0,0052
CL 8X16	8	19	21,5	16	37	30	8	0,0106
CL 8X32	8	19	21,5	32	52	46	8	0,0116
CL 10X20	10	23	26	20	46	38	10	0,0194
CL 10X40	10	23	26	40	66	58	10	0,0205
CL 12X24	12	28	31	24	53	45	12	0,0331
CL 12X48	12	28	31	48	78	69	12	0,0350
CL 14X28	14	31	34	28	62	52	14	0,0472
CL 14x56	14	31	34	56	92	82	14	0,0508
CL 16X32	16	36	39	32	73	62	16	0,0694
CL 16X64	16	36	39	64	103	92	16	0,0744
CL 20X40	20	45	50	40	87,5	71,5	16	0,1300

CL18x36 disponibile su richiesta *available under request*

Forcelle ed accessori / Clevises and accessories

Clips per forcelle ex CNomo

Spring pins for ex CNomo clevises

Sigla Designation	Dimensioni mm Dimensions mm							Peso Weight
	d h11	a	b	g	L ₁ ≈	L ₂ ≈	L ₃ ≈	≈ Kg
CL 8X16 CN	8	25	28	16	41	36	10	0,014
CL 12X25 CN	12	40	44	25	60	50	12	0,043
CL 16X33 CN	16	49	53	33	74	63	15	0,090
CL 20X40 CN	20	69	73	40	98	81	19	0,193

Su richiesta, disponibili in acciaio inox ed alluminio
Under request, stainless steel and aluminium available

Perni con testa cilindrica per coppiglia

Pins with cylindrical head for split pins

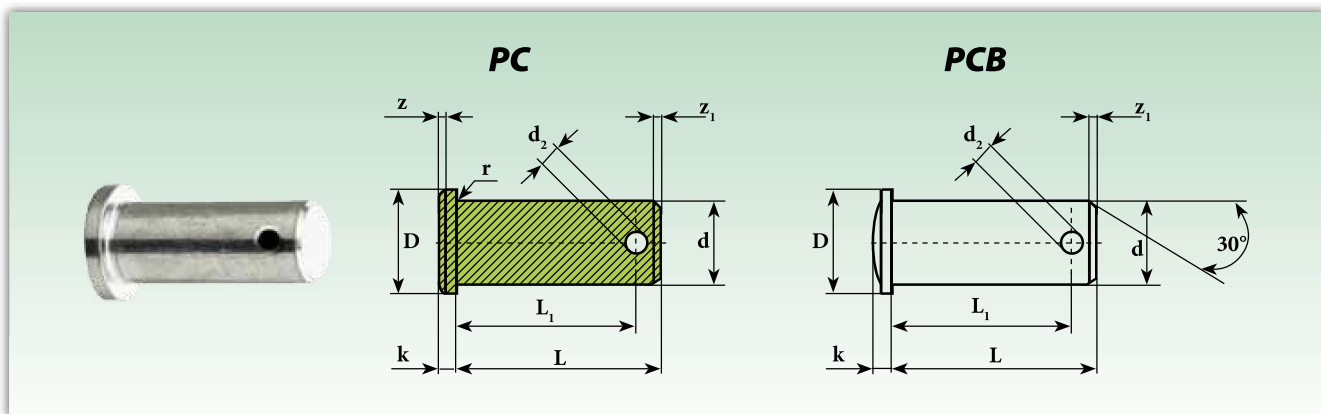

Sigla Designation	Dimensioni mm Dimensions mm									Peso Weight
	d h11	d ₂ H14	D h12	k js14	L +0,3 ≈ 0	L ₁ +0,5 ≈ 0	r	z	z ₁ ≈	≈ Kg
PC 4	4	1	6	1	12	10	0,3	0,5	0,8	0,001
PC 5	5	1,2	8	1,5	15	12,3	0,3	0,5	0,8	0,003
PC 6	6	1,6	9	1,5	18	15,3	0,5	0,5	1	0,005
PC 8	8	2	12	2	23	19,5	0,5	1	1	0,010
PC 10	10	3,20	14	2	29	24,5	0,5	1	1,5	0,019
PC 12	12	4	17	3	35	29,5	0,5	1,5	2	0,034
PC 14	14	4	20	3	40	32,5	1	1,5	2,5	0,053
PC 16	16	4	21	3	45	37,5	1	1,5	2,5	0,067
PC 18	18	5	25	3,5	50	43,5	1	1,5	3	0,140
PC 20	20	5	26	4	54	47	1	2	3	0,125
PC 25	25	6	32	5	67	59	1	2	3	0,260

Perni con testa bombata (sferica) per coppiglia

Pins with barell head (spherical) for split pins

Sigla Designation	Dimensioni mm Dimensions mm							Peso Weight
	d h11	d ₂ H14	D	k js14	L +0,3	L ₁ +0,5	z ₁ ≈	≈ Kg
PCB 16	16	4	20	3,5	45	38,2	1,5	0,072
PCB 18	18	5	25	3,5	50	43,5	1,5	0,104
PCB 20	20	5	28	4	53	47	1,5	0,139
PCB 25	25	6,3	34	5,5	67	59	1,5	0,266
PCB 28	28	6,3	34	5,5	72	63,2	2	0,361
PCB 30.6	30	6,3	36	5,5	67	59	2	0,383
PCB 30.7	30	6,3	36	5,5	77	68,2	2	0,428
PCB 35	35	8	45	7	87	76,5	2	0,677
PCB 40	40	8	48	6	100	90	5	1,035
PCB 42	42	8	48	7	100	90	5	1,151
PCB 50	50	10	58	7	115	103	6	1,846

Su richiesta, disponibili in acciaio inox ed alluminio
Under request, stainless steel and aluminium available

Perni con testa cilindrica per molla

Pins with cylindrical head for spring

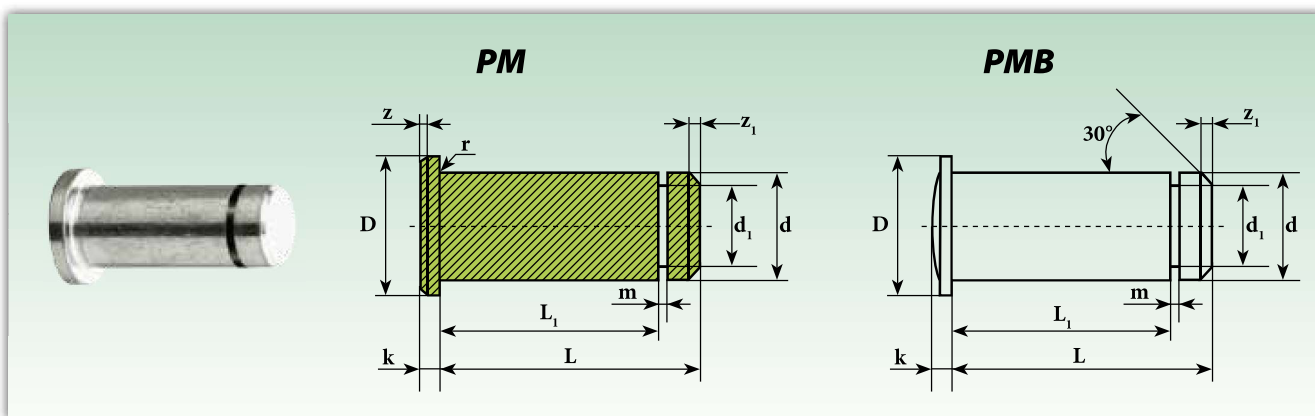

Sigla Designation	Dimensioni mm Dimensions mm											Peso Weight ≈ Kg
	d h11	d ₁ h11	D h12	k js14	L +0,3 ≈ 0	L ₁ +0,3 ≈ 0	m +0,1 ≈ 0	r	z ≈	z ₁ ≈		
PM 4	4	3,2	6	1	10,5	8,5	0,64	0,3	0,5	0,5	0,002	
PM 5	5	4	8	1,5	13	10,5	0,74	0,5	0,5	0,5	0,003	
PM 6	6	5	9	1,5	15,5	12,5	0,74	0,5	0,5	0,75	0,004	
PM 8	8	6	12	2	20	16,5	0,94	0,5	1	1	0,009	
PM 10	10	8	14	2	25	20,5	1,05	0,5	1	1	0,017	
PM 12	12	9	17	3	30	24,5	1,15	0,5	1,5	1,25	0,030	
PM 14	14	10	19	3	33	27,5	1,25	1	1,5	1,5	0,048	
PM 16	16	12	20	3	38,5	32,5	1,35	1	1,5	1,5	0,067	
PM 18	18	13	25	3,5	42	36,5	1,35	1	2	1,5	0,895	
PM 20	20	17,5	26	4	46	40,5	1,8	1	2	1,5	0,125	
PM 25	25	18	32	5	57	50,5	1,8	1	2	1,5	0,260	

Perni con testa bombata (sferica) per molla

Pins with barrel head (spherical) for spring

Sigla Designation	Dimensioni mm Dimensions mm									Peso Weight ≈ Kg
	d h11	d ₁ h11	D h12	k js14	L +0,3	L ₁ +0,3	m +0,1	z ₁ ≈		
PMB 14	14	10	20	2,5	33	27,5	1,25	1,25	0,041	
PMB 16	16	12	20	3,5	38,5	32,5	1,35	1,5	0,062	
PMB 18	18	13	25	3,5	42	36,5	1,35	1,5	0,090	
PMB 20	20	17,5	28	4	46	40,5	1,80	1,5	0,121	
PMB 25	25	18	34	5,5	57	50,5	1,80	1,5	0,231	

Su richiesta, disponibili in acciaio inox ed alluminio
Under request, stainless steel and aluminium available

Perni per forcelle

Pins for clevises

PS-PS..CN

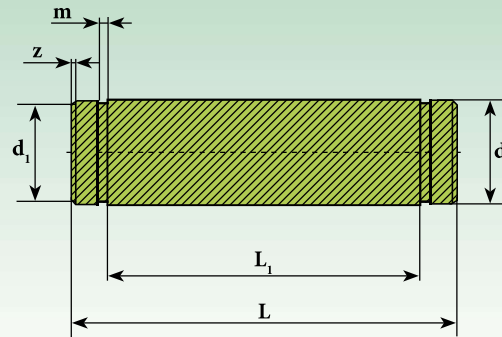

Sigla Designation	Dimensioni mm Dimensions mm						Peso Weight
	d h11	d ₁ h11	L +0,4 ≈ 0	L ₁ +0,3 ≈ 0	m H13	z ≈	≈ Kg
PS 5	5	4,8	15	10,5	0,7	1	0,003
PS 6	6	5,7	17	12,2	0,8	1	0,005
PS 8	8	7,6	20	16,5	0,9	1	0,008
PS 10	10	9,6	25	20,5	1,1	1	0,015
PS 12	12	12	30	24,5	1,1	1	0,026
PS 14	14	13	35	27,5	1,1	1	0,042
PS 16	16	15	39	32,5	1,1	1	0,061
PS 20	20	19	48	40,5	1,3	1	0,118
PS 25	25	24	60	50,5	1,3	1	0,230
PS 30	30	29	65	55,5	1,6	1	0,350
PS 35	35	33	84	70,5	1,6	1	0,620

Forcelle ed accessori / Clevises and accessories

Perni per forcelle ex CNomo

Pins for ex CNomo clevises

Sigla Designation	Dimensioni mm Dimensions mm						Peso Weight
	d h11	d ₁ h11	L +0,4 ≈ 0	L ₁ +0,3 ≈ 0	m H13	z ≈	≈ Kg
PS 8 CN	8	7,6	30	22	0,9	1	0,012
PS 12 CN	12	11,5	45	36	1,1	1	0,039
PS 16 CN	16	15,2	55	45	1,1	1	0,085
PS 20 CN	20	19	75	63	1,3	1	0,185
PS 25 CN	25	23,9	95	80	1,3	1	0,360

Su richiesta, disponibili in acciaio inox
Under request, stainless steel available

Rondelle per perni

Washers for pins

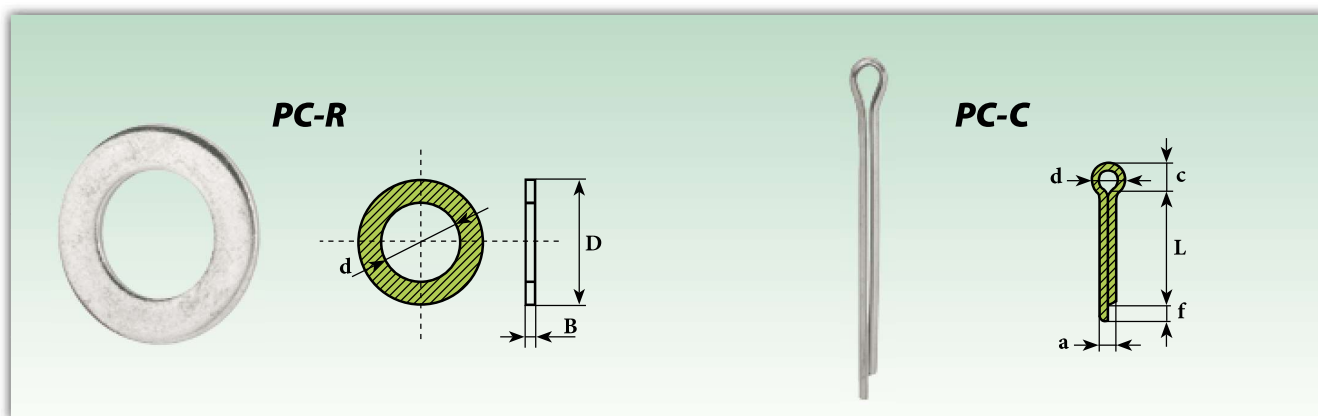

Sigla Designation	Dimensioni mm Dimensions mm			Peso ¹⁾ Weight ¹⁾
	d	D	B	≈ Kg
PC-R 4	4,3	7,5	0,8	0,15
PC-R 5	5,3	9,5	1	0,39
PC-R 6	6,4	11	1,6	0,70
PC-R 8	8,4	15	1,6	1,52
PC-R 10	10,5	18	1,6	2,11
PC-R 12	13	20	2	2,85
PC-R 14	15	24	2	4,30
PC-R 16	17	27	2	5,42
PC-R 20	21	33	2,5	9,98
PC-R 25	25	39	4	14,50

¹⁾ Peso riferito a 1.000 pezzi Weight ref. 1.000 pcs.

Copiglie per perni

Split pins for pins

Sigla Designation	Dimensioni mm Dimensions mm				
	d	a	c	f	L
PC-C 4	1,5	1	2,5	1,5	10
PC-C 5/6	3,6	1,6	4	2,5	10
PC-C 8	5,8	2	6,4	3,2	16
PC-C 10	7,4	3,2	8	4	20
PC-C 12/16	7,4	4	8	4	32
PC-C 20/25	9,2	4	10	4	32

Su richiesta, disponibili in acciaio inox ed alluminio
Under request, stainless steel and aluminium available

Molle per perni

Safety clips

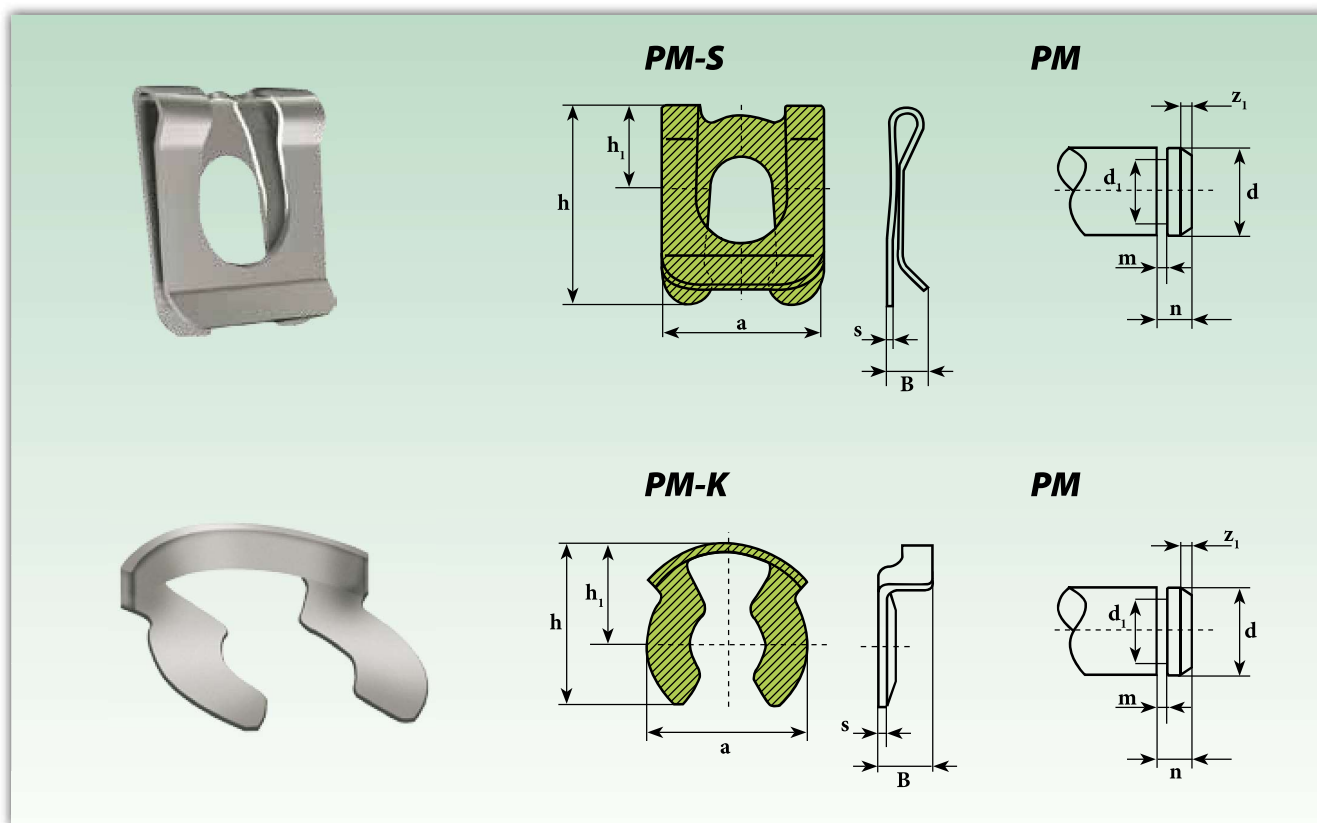

Forcelle ed accessori / Clevises and accessories

Sigla Designation	Dimensioni mm Dimensions mm										Forza assiale max Max strength (daN)
	d_{h11}	d_{1h11}	a_{\approx}	B	h_{\approx}	$h_{1\approx}$	$m_{+0,1\approx 0}$	$n_{+0,3\approx 0}$	s	$z_{1\approx}$	
PM-S 4	4	3,2	7	2,3	8,5	4	0,64	2	0,3	0,50	100
PM-S 5	5	4	9	3,3	10,7	5	0,74	2,5	0,4	0,50	130
PM-S 6	6	5	11	3,8	14,1	6	0,74	3	0,4	0,75	150
PM-S 8	8	6	14	4	17,5	8	0,94	3,5	0,5	1	360
PM-S 10	10	8	18	5	22,1	10	1,05	4,5	0,5	1	640
PM-S 12	12	9	22	5	26	12	1,15	5	0,5	1,25	960
PM-S 14	14	10	25	6	30	13,5	1,25	5,5	0,6	1,5	1.130
PM-S 16	16	12	28	6	34	16	1,35	6	0,6	1,5	1.350

Sigla Designation	Dimensioni mm Dimensions mm										Forza assiale max Max strength (daN)
	d_{h11}	d_{1h11}	a_{\approx}	B	h_{\approx}	$h_{1\approx}$	$m_{+0,1\approx 0}$	$n_{+0,3\approx 0}$	s	$z_{1\approx}$	
PM-K 4	4	3,2	6,5	2,7	7	4,3	0,64	2	0,4	0,50	150
PM-K 5	5	4	7,5	2,8	8,7	5,2	0,74	2,5	0,5	0,50	300
PM-K 6	6	5	10,4	3,5	11,5	6,8	0,74	3	0,5	0,75	485
PM-K 8	8	6	11,5	4,1	12,1	7,2	0,94	3,5	0,5	1	550
PM-K 10	10	8	15,6	5,9	16,3	9,5	1,05	4,5	0,6	1	950
PM-K 12	12	9	16,7	6,1	18	10,5	1,15	5	0,6	1,25	1.070
PM-K 14	14	10	19	6,5	20	11,5	1,25	5,5	0,7	1,5	1.270
PM-K 16	16	12	22,7	7,8	23,5	13,8	1,35	6	0,8	1,5	1.400
PM-K 20-25	20-25	16-18	34,5	9	34	20	1,8	8	1	1,5	1.600

Su richiesta, disponibili in acciaio inox ed alluminio
Under request, stainless steel and aluminium available